

2nd Nepal Virtual Workshop in Flow Cytometry 2021

Central Department of Biotechnology  
Tribhuvan University  
Kathmandu, Nepal

4-7 May 2021

**Agenda**

Seminar: [Basic multicolor flow cytometry: Fluorochromes, panel design, setup and compensation \(Day 1\)](#) - Zosia Mactiorowski

Seminar: [Fluorescence Compensation and Panel Design \(Day 1\)](#) - Derek Davies

Seminar: [Immunofluorescence labeling for flow cytometry \(Day 2\)](#) - Paul Hutchinson

Seminar: [Data acquisition on the BD FACSCalibur flow cytometer \(Day 3\)](#) - Bill Telford

Seminar: [Analysis of DNA cell cycle and cell proliferation by flow cytometry \(Day 4\)](#) - Paul Wallace

Video: Day 1  
Video: Day 2  
Video: Day 3  
Video: Day 4

Chat: Day 1  
Chat: Day 2  
Chat: Day 3  
Chat: Day 4

ISAC CYTO Virtual Interactive Conference 2021:  
<https://www.cytoconference.org>

Website from 1st Nepal Virtual Flow Cytometry Workshop (February 2021):  
[https://www.cytometryunderground.com/TU\\_Flow\\_2021.html](https://www.cytometryunderground.com/TU_Flow_2021.html)

CYTO University (CYTO U):  
<https://learning.isac-net.org/>

OpenFlow Cytometry Video Lectures (Derek Davies, Francis Crick Institute)  
<https://www.youtube.com/channel/UCadgNlgcf6Zvu1HVGkvwp0w>

Crick Webinars (Derek Davies, Francis Crick Institute)  
[https://www.youtube.com/playlist?list=PLpAyGqPO0aHrmHgwSV4oiU0M9G\\_j4wCXs](https://www.youtube.com/playlist?list=PLpAyGqPO0aHrmHgwSV4oiU0M9G_j4wCXs)

Workshop link:

[https://www.cytometryunderground.com/TU\\_Flow\\_2\\_2021.html](https://www.cytometryunderground.com/TU_Flow_2_2021.html)

CYTO Virtual Interactive Conference 2021:

<https://www.cytoconference.org>

CYTO University (CYTO U):

<https://learning.isac-net.org/>

OpenFlow Cytometry Video Lectures (Derek Davies, Francis Crick Institute)

<https://www.youtube.com/channel/UCadgNlgcf6Zvu1HVGkvwp0w>

Crick Webinars (Derek Davies, Francis Crick Institute)

[https://www.youtube.com/playlist?list=PLpAyGqPO0aHrmHgwSV4oiU0M9G\\_j4wCXs](https://www.youtube.com/playlist?list=PLpAyGqPO0aHrmHgwSV4oiU0M9G_j4wCXs)

# 2<sup>nd</sup> Nepal Virtual Flow Cytometry Workshop

4-7 May 2021

Central Department of Biotechnology,

Tribhuvan University

Kathmandu Nepal

**Day 3**

**6 May 2021**

17:00 - 18:30

**Operation of the BD FACSCalibur flow cytometer (Interactive)**

Bill Telford and multiple faculty

*Live demonstration of the features and operation of a BD FACSAria flow cytometry, including simple cell analysis. With live commentary by multiple faculty.*

18:30 - 19:00

Discussion

All times are Nepal Time. All meetings start at 17:00 Nepal.

[https://www.cytometryunderground.com/TU\\_Flow\\_2\\_2021.html](https://www.cytometryunderground.com/TU_Flow_2_2021.html)

BD Biosciences FACSCalibur

# Introducing FACSCalibur.



## A New Legend Begins.

For over two decades, Becton Dickinson's tradition of advanced technology and innovative solutions has been legendary in the industry. Now with FACSCalibur™, our new automated, four-color flow cytometry system, the legend continues.

FACSCalibur is the only four-color benchtop system that both analyzes and sorts, making it the ideal choice for labs performing multiple applications. With its automated loader, broad range of reagents, and powerful software applications, FACSCalibur offers the fast throughput necessary to meet productivity requirements and provides the flexibility and performance that are essential for today's laboratory environment.

FACSCalibur can quickly perform routine tests for immunophenotyping, lymphocyte subset analysis with absolute counts\*, reticulocyte enumeration, and DNA analysis\*. It can give investigators the sensitivity and resolution so crucial for sophisticated cellular work in genetics, molecular biology, multicolor analysis, and immune function. And with FACSCalibur, you can sort cells of interest for further study, adding another dimension to the information you gain.

To discover how the new FACSCalibur system can make a difference in the productivity and performance of your laboratory, contact your local Becton Dickinson representative today.

FACSCalibur: A new legend begins.

The research pioneer.  
The clinical leader.

**BECTON  
DICKINSON**

Becton Dickinson  
Immunocytometry Systems  
United States  
(800) 223-8226

Becton Dickinson  
Canada, Inc.  
Canada  
(905) 872-4820

Becton Dickinson  
European HQ  
Europe  
(32) 53-72021

Nippon Becton Dickinson  
Company, Ltd.  
Japan  
(81) 3-3403-9994

\*For Research Use Only

Becton Dickinson  
Worldwide Inc.  
Singapore  
(65) 861-0633

# BD FACSCalibur at Tribhuvan University



# BD FACSCalibur at Tribhuvan University



# BD FACSCalibur flow cytometer

Two lasers, four colors

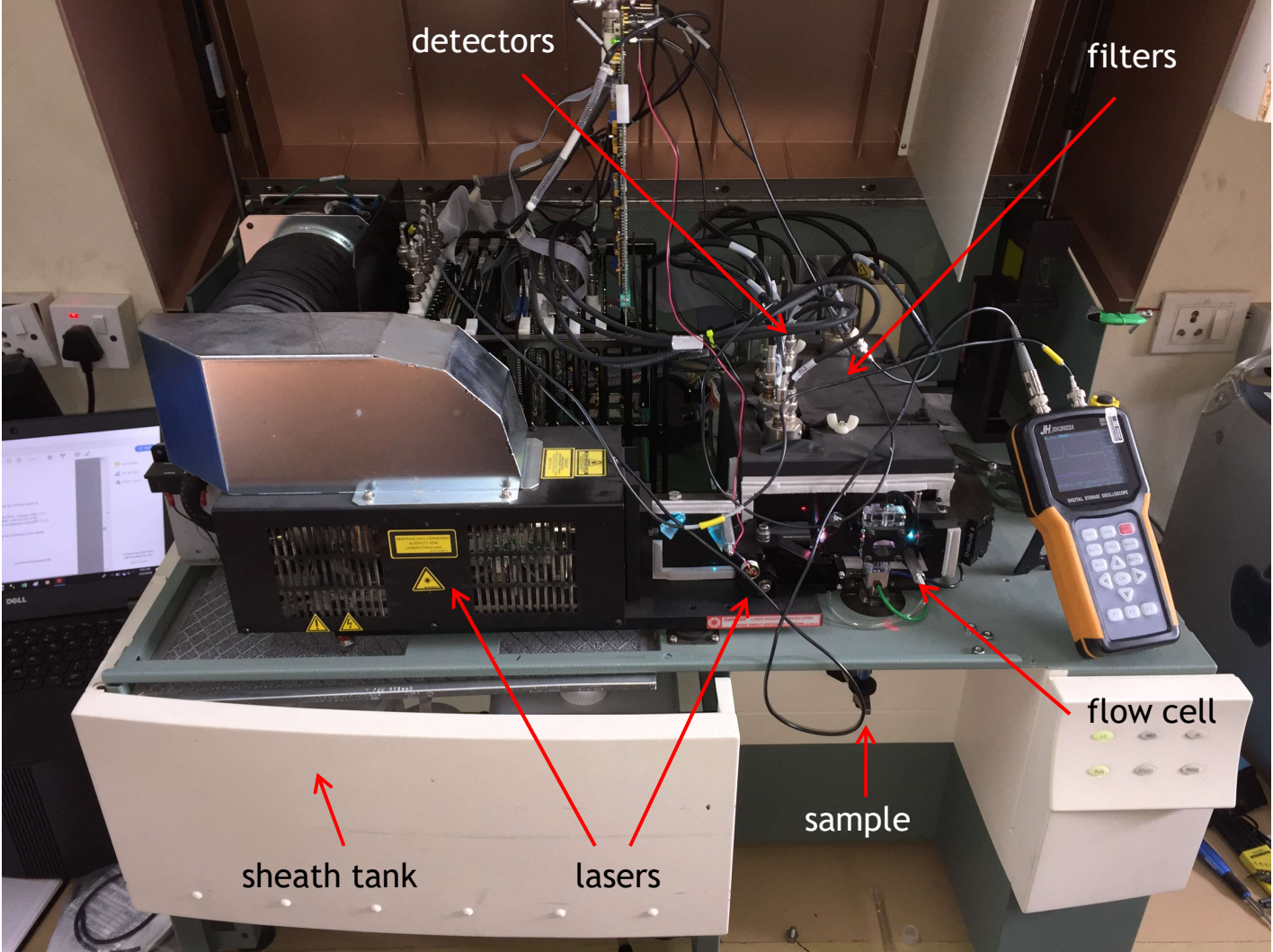

# BD Biosciences FACSCalibur lasers

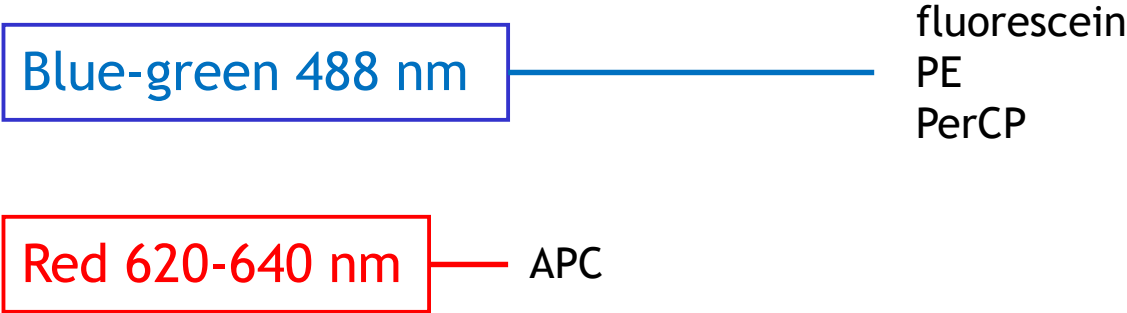

The FACSCalibur has two lasers. Three fluorescent probes can be detected using the blue-green 488 nm laser, and one with the red 640 nm laser.

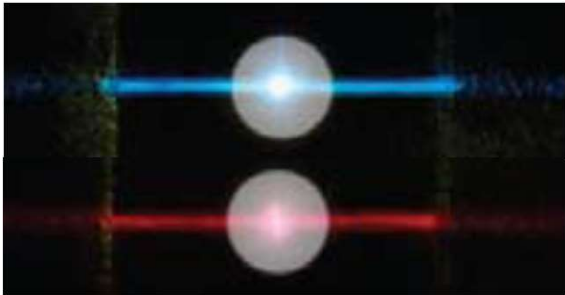

# BD Biosciences FACSCalibur detectors

Four fluorescence detectors, three off the 488 nm, one off the 640 nm laser.

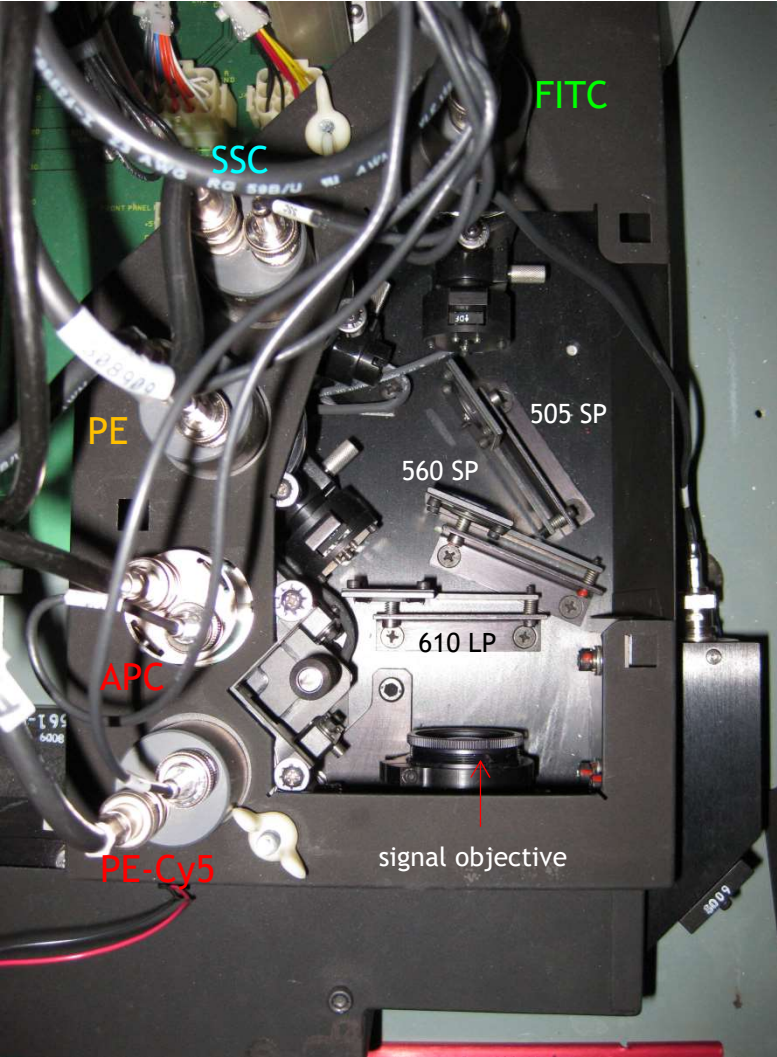
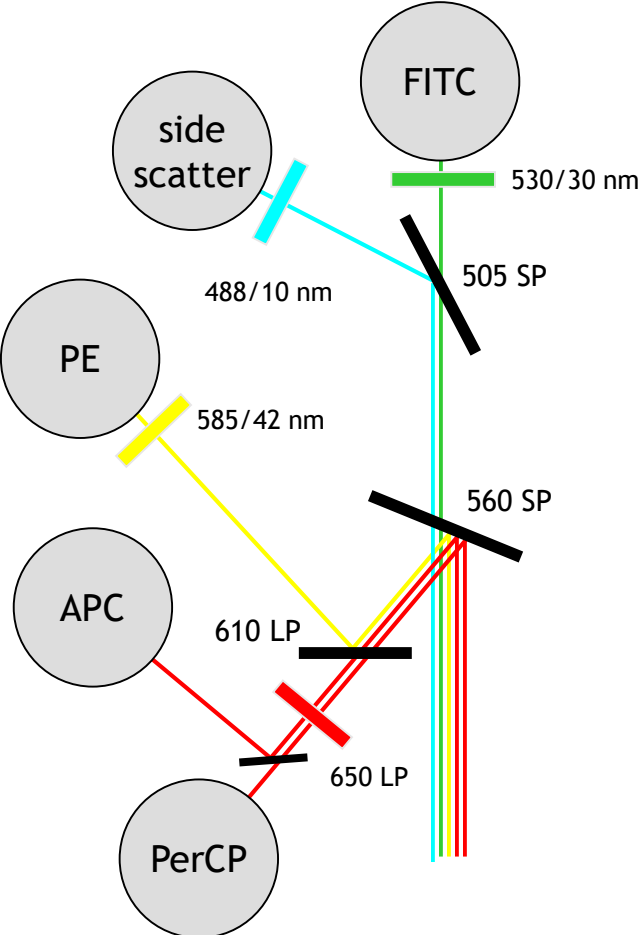

# BD Biosciences FACSCalibur lasers and detectors

The FACSCalibur can detect up to four colors.

**Fluorescein** is the most common green fluorochrome, but **Alexa Fluor 488** and **GFP** can be detected too. **PerCP** or **PE-Cy5** can be detected in the long red detector.

**APC** is detected using the red laser, but **Cy5** and **Alexa Fluor 647** are used too.

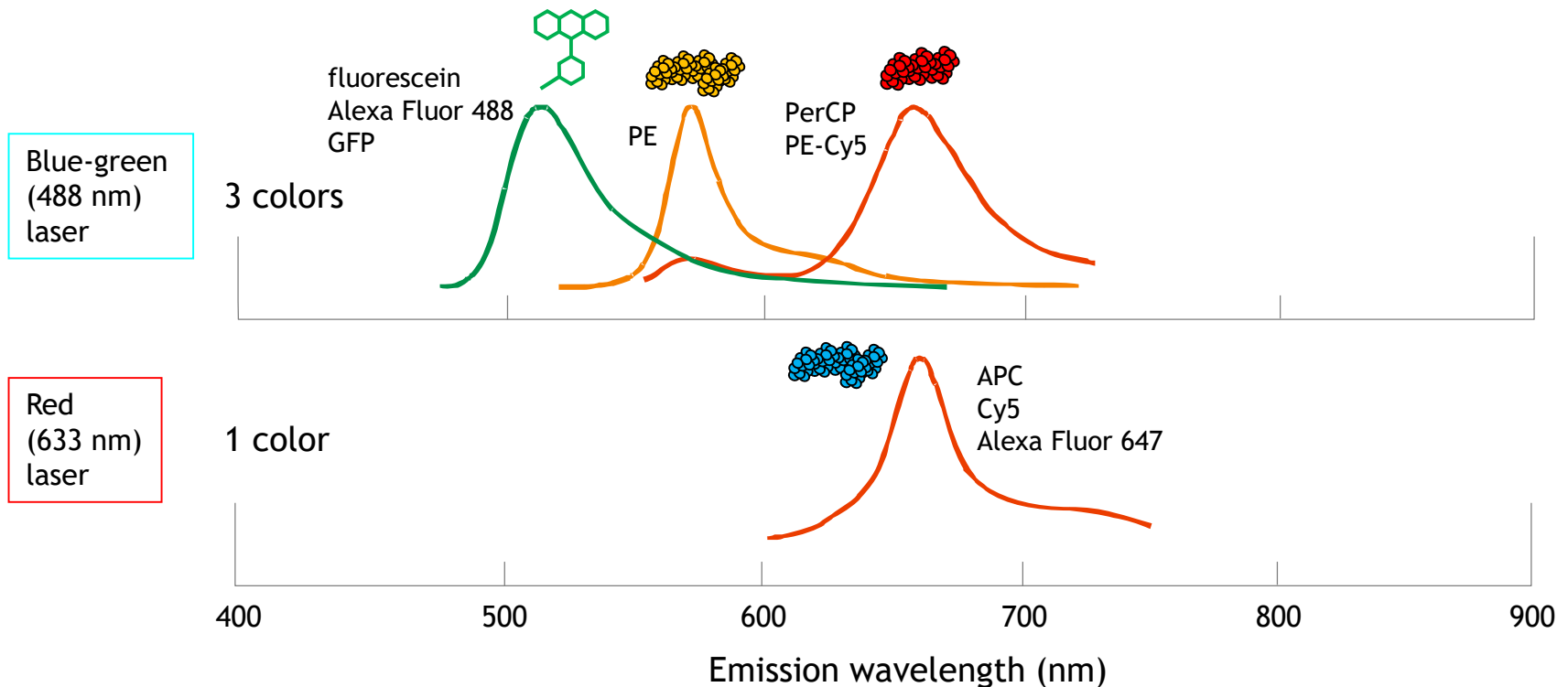

# Four color analysis of peripheral blood

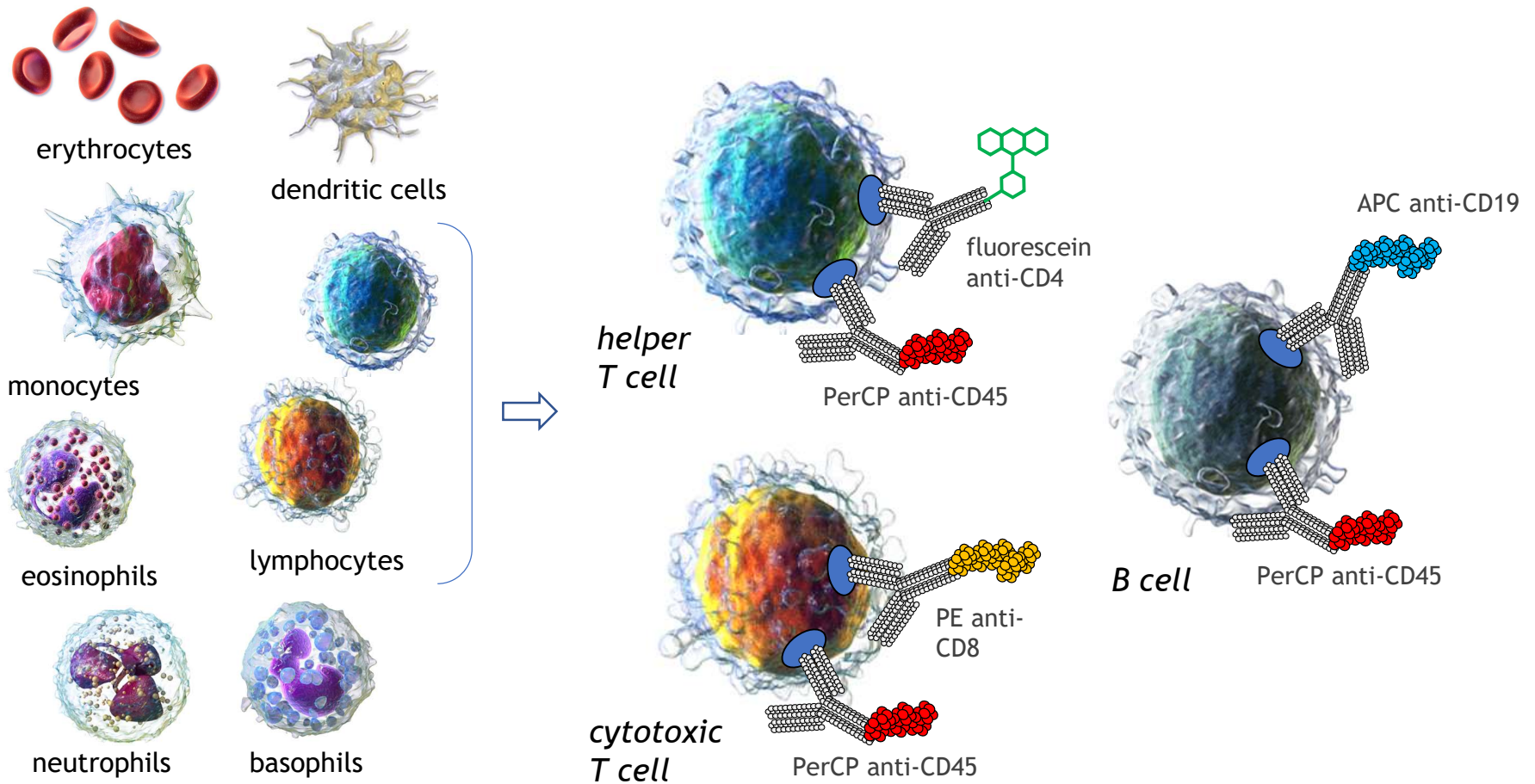

# Labeling peripheral blood for flow cytometry

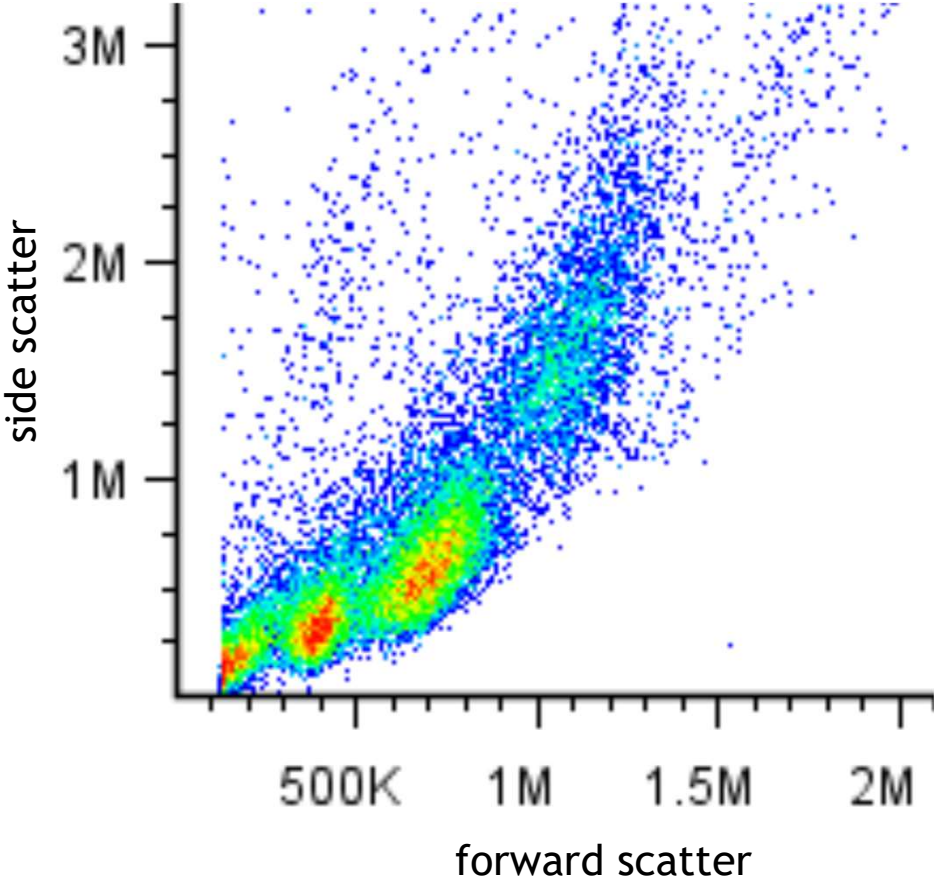
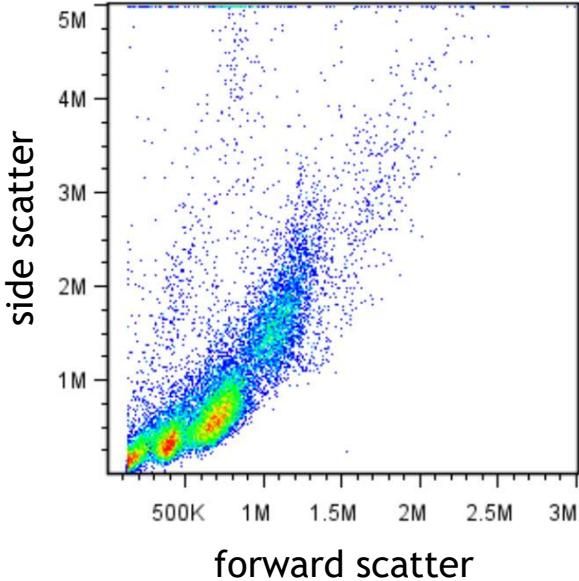

# Labeling peripheral blood for flow cytometry

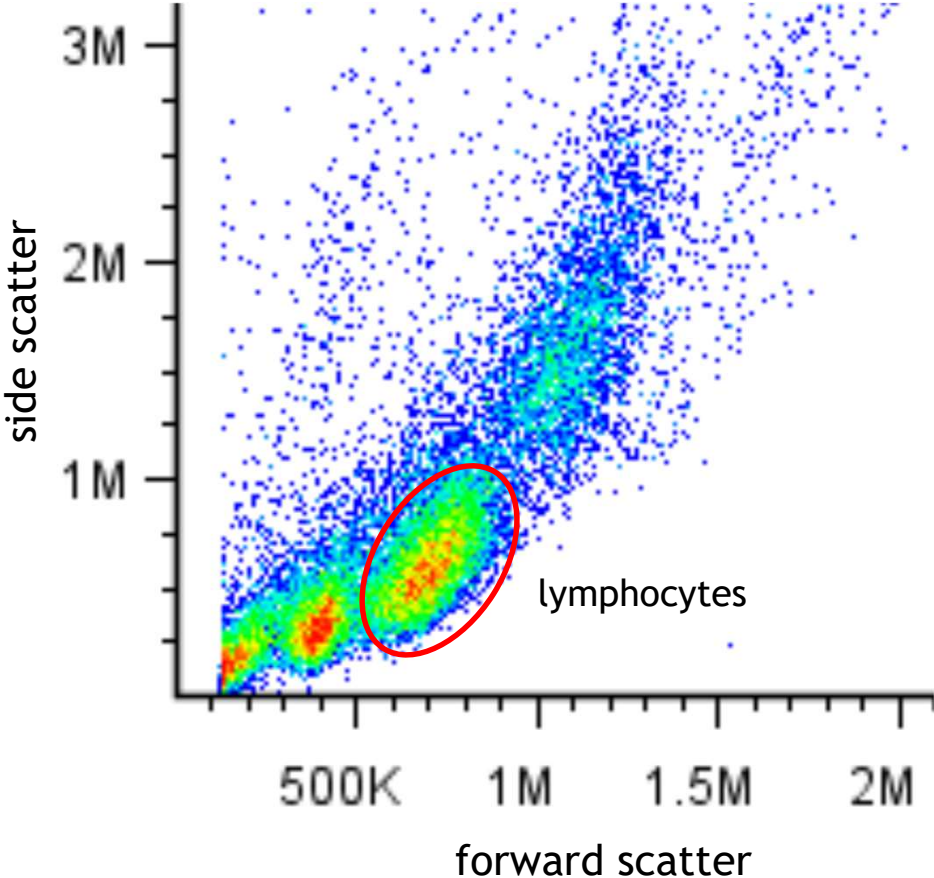
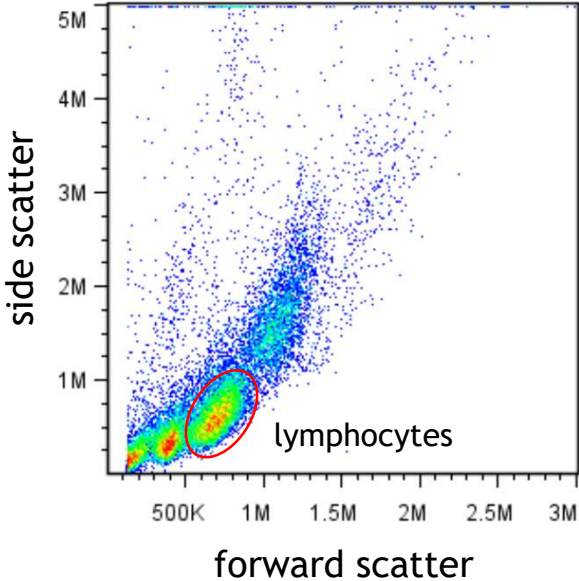

# Labeling peripheral blood for flow cytometry

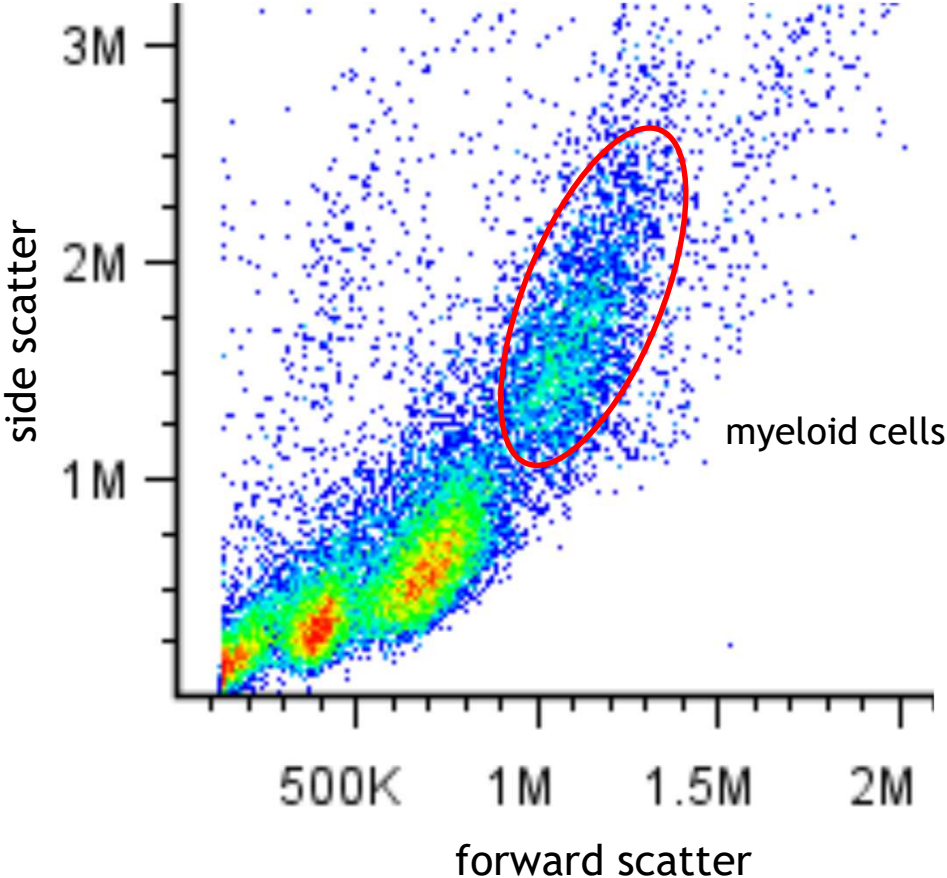
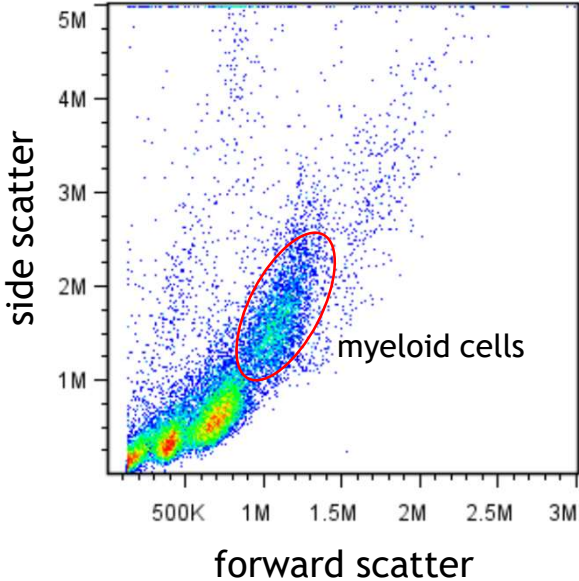

# Labeling peripheral blood for flow cytometry

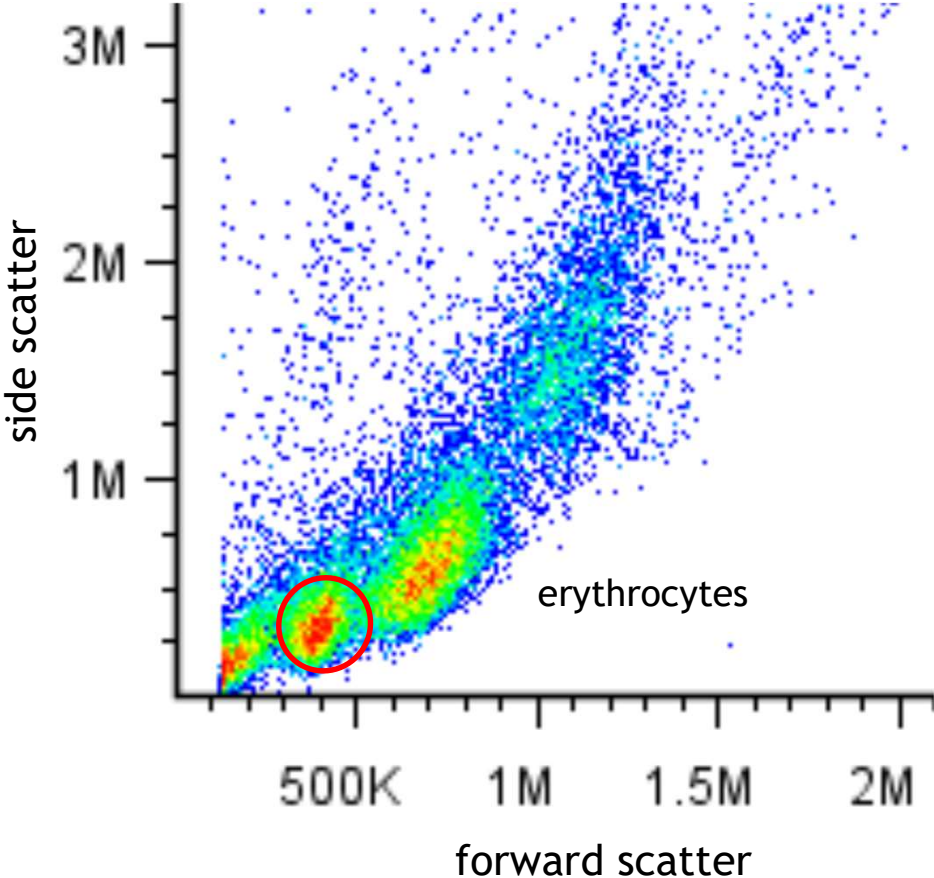
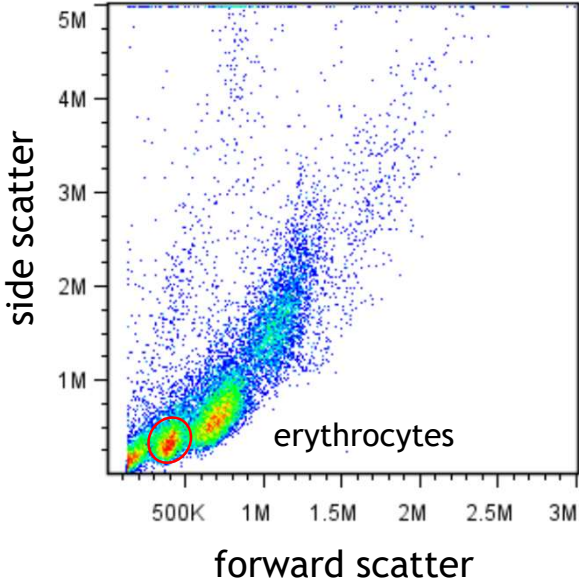

# Labeling peripheral blood for flow cytometry

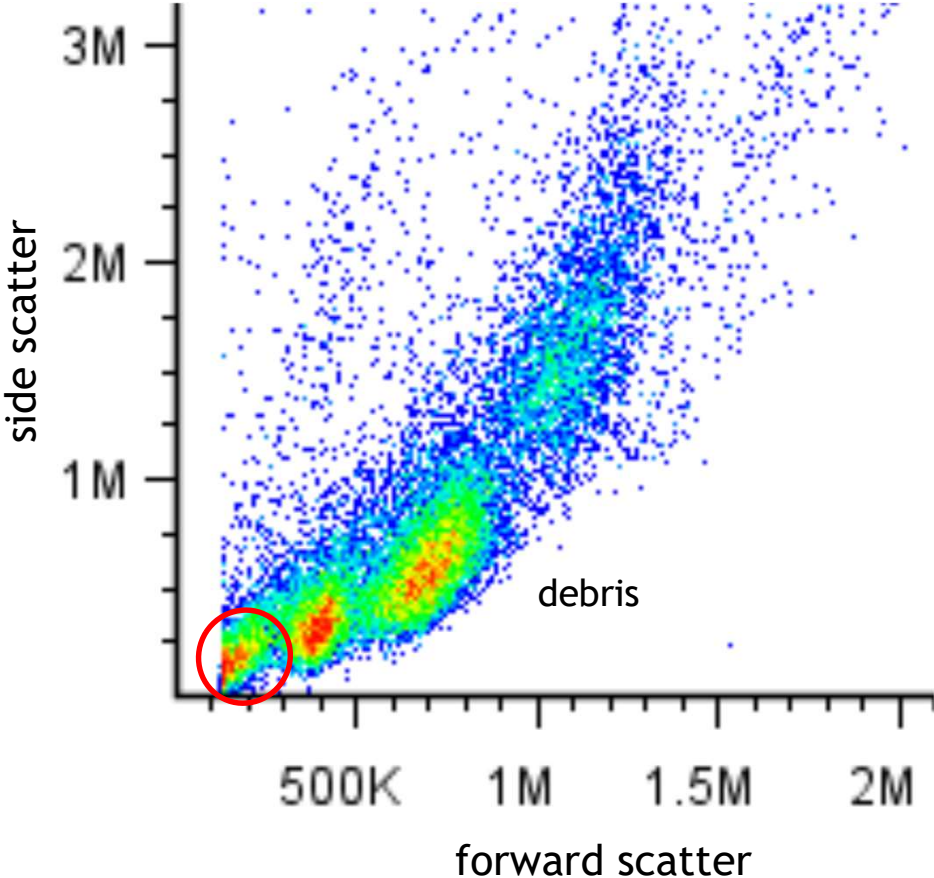
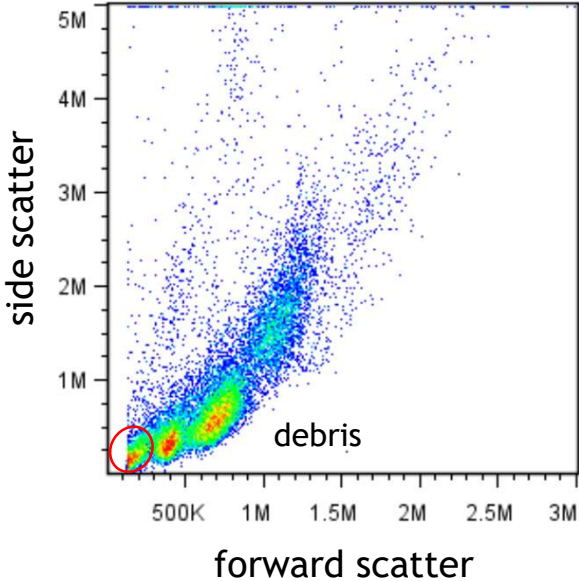

# Labeling peripheral blood for flow cytometry

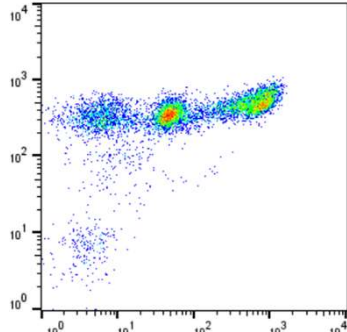
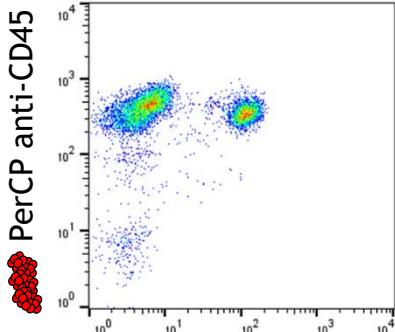
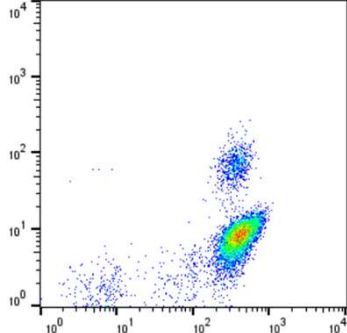
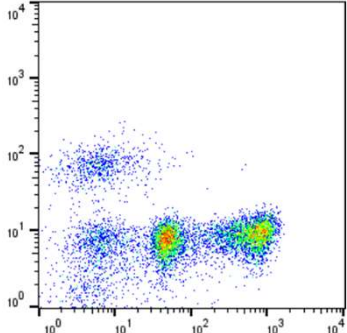
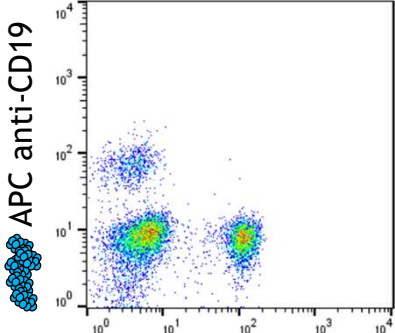
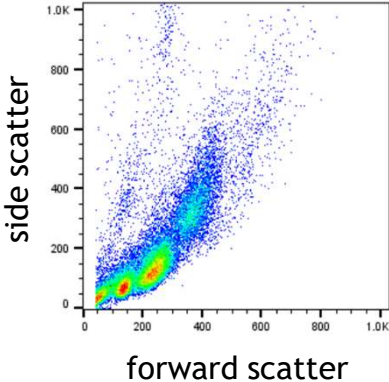

PerCP anti-CD45

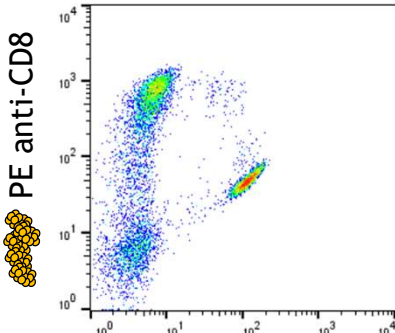

FITC anti-CD4

no compensation

# Labeling peripheral blood for flow cytometry

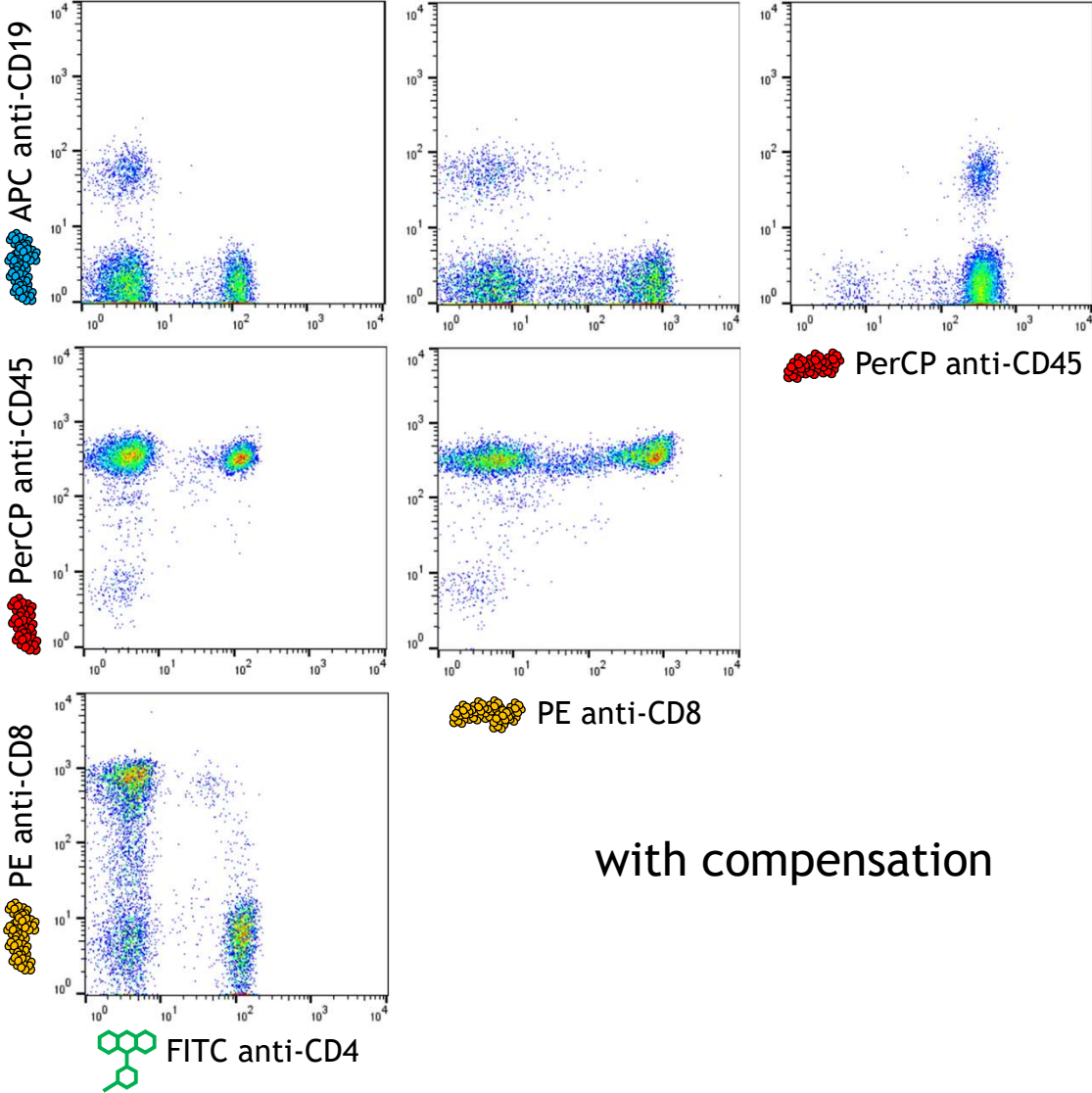
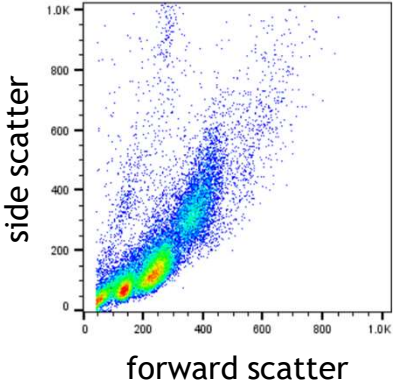

PerCP anti-CD45

PE anti-CD8

with compensation

# Labeling peripheral blood for flow cytometry

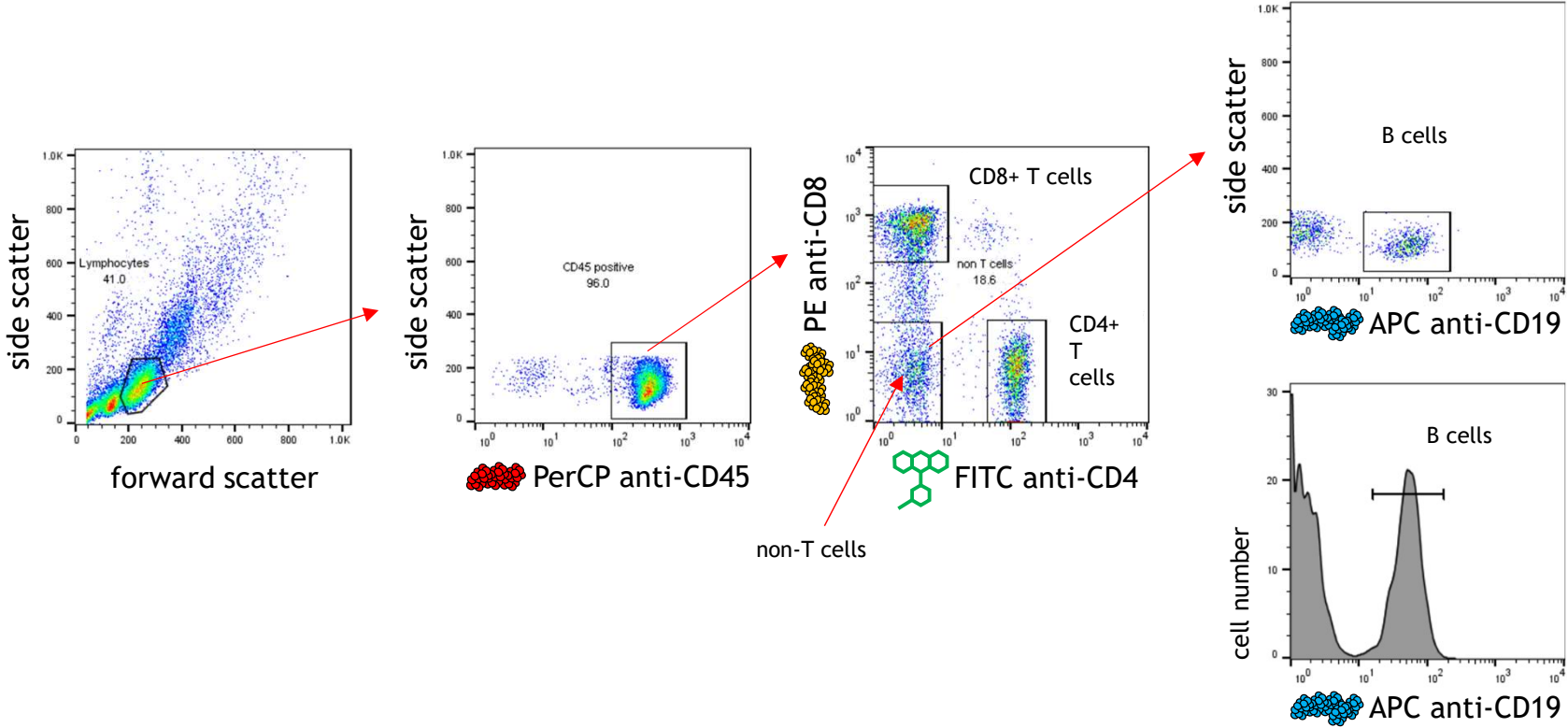

# Compensation

Some of these fluorochromes overlap spectrally with others.

Some are excited by both laser wavelengths and have similar emission spectra.

We will need to determine the **compensation matrix** for these fluorochromes (either manually or automatically).

